

**SINGLE STAGE  
SIDE ACCESS  
FLAT BANK HOUSING  
FOR ASHRAE RATED  
PREFILTERS**

**FEATURES:**

- ☑ Available in Three Stock Depths
- ☑ Available in Galvanized and Stainless Steel
- ☑ Welded Construction
- ☑ Corner Supports for Rigidity
- ☑ Flexible in Possible Filter Options
- ☑ Positive Tension, Gasketed Doors
- ☑ Perform up to  $\pm 3''$  W.G.
- ☑ Factory Installed Flange
- ☑ Large List of Options

The TRI-MET FB™ air filter housing is designed to hold ASHRAE rated air filters. The TRI-MET FB™ comes in the standard filter depths of 2", 4" or 6".

The TRI-MET FB™ is fabricated from galvanized steel or optional stainless steel and is welded together without any bolt connections. The TRI-MET FB™ features one-piece construction with a fabricated U channel to hold the filters. Upstream corner supports increase the rigidity of the unit. Each TRI-MET FB™ is manufactured to meet end user requirements.

The TRI-MET FB™ housing accommodates different types and efficiencies of air filters. With 4" deep filters, the housing can operate at face velocities up to 625 FPM, depending on airflow limitations of selected air filters.

Positive tension door locks make filter servicing easy and combined with a perimeter gasketing around the door ensures a positive seal. Straight seams on the TRI-MET FB™ housings are intermittently welded and silicone caulked to prevent air leakage. The TRI-MET FB™ is able to perform up to  $\pm 3''$  W.G.

Factory installed flange on the TRI-MET FB™ is suitable for connection to either ductwork or air handler system. The TRI-MET FB™ is perfect for installation where space limitations exist.

The TRI-MET FB™ comes with a large number of options so housings can be customized to meet any application specific requirements.

# TRI-MET FB™ Options

- ▲ Vertical Flow Application
- ▲ Weather Cover
- ▲ Bottom Access
- ▲ Lifting Lugs
- ▲ Transitions
- ▲ Custom and Drilled Flanges
- ▲ Double Wall Insulation
- ▲ Static Port(s)
- ▲ Magnehelic Gauge
- ▲ Oil Mist Collection Configuration

# TRI-MET FB™ Drawing

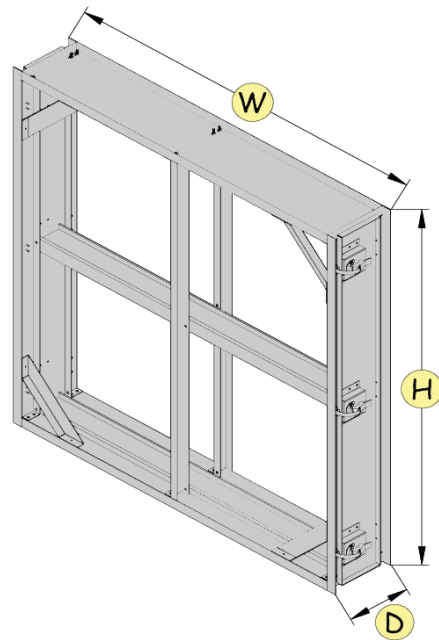

# TRI-MET FB™ Specifications

LEGEND Capacity Dimensions (HxW) Number of Filters Face Area (Sq. Ft.)		Unit Width			
		1	2	3	4
Unit Height	1	2,000 CFM 26-7/8"x26-1/8" 1-24x24 Filter 4 Sq Ft	4,000 CFM 26-7/8"x49-1/2" 2-24x24 Filter 8 Sq Ft	6,000 CFM 26-7/8"x72-7/8" 3-24x24 Filter 12 Sq Ft	8,000 CFM 26-7/8"x96-1/4" 4-24x24 Filter 16 Sq Ft
	2	4,000 CFM 51"x26-1/8" 2-24x24 Filter 8 Sq Ft	8,000 CFM 51"x49-1/2" 4-24x24 Filter 16 Sq Ft	12,000 CFM 51"x72-7/8" 6-24x24 Filter 24 Sq Ft	16,000 CFM 51"x96-1/4" 8-24x24 Filter 32 Sq Ft
	3	6,000 CFM 75-1/8"x26-1/8" 3-24x24 Filter 12 Sq Ft	12,000 CFM 75-1/8"x49-1/2" 6-24x24 Filter 24 Sq Ft	18,000 CFM 75-1/8"x72-7/8" 9-24x24 Filter 36 Sq Ft	24,000 CFM 75-1/8"x96-1/4" 12-24x24 Filter 48 Sq Ft
	4	8,000 CFM 99-1/4"x26-1/8" 4-24x24 Filter 16 Sq Ft	16,000 CFM 99-1/4"x49-1/2" 8-24x24 Filter 32 Sq Ft	24,000 CFM 99-1/4"x72-7/8" 12-24x24 Filter 48 Sq Ft	32,000 CFM 99-1/4"x96-1/4" 16-24x24 Filter 64 Sq Ft

## NOTES

**Capacity** is reported in CFM at a flow rate of 500 FPM

**Dimensions** are reported in exact size in inches and Height x Width

**Number of Filters** are reported in quantity and nominal dimensions

**Face Area** is reported as face area of air filters – nominal size in square feet

**Standard Housing Depths** relative to filter depth  
 2" Filter = 8-1/2"  
 4" Filter = 8-1/2"  
 6" Filter = 12"

**Special and Half Size Units** are available

Tri-Dim Filter Corporation is committed to continual product development – all descriptions, specifications and performance data are subject to change without notice.

Tri-Dim® and Tri-Dek® are Registered Trademarks of Tri-Dim Filter Corporation. Tri-Met™ is a Trademark of Tri-Dim Filter Corporation.



TRI-DIM FILTER CORPORATION  
 P.O. BOX 466 • 93 INDUSTRIAL DRIVE  
 LOUISA, VA 23093

(540) 967-2600 • FAX: (540) 967-2835

EMAIL: info@tridim.com • Website: www.tridim.com  
 TOLL FREE 1-800-458-9835

## Local Representation: